

ECOTUBE 2010 Diffusers



Specifications



Size:	65 mm OD x 1000 mm long
Membrane:	MOC : EPDM compound (or) Silicone Slit size: normally 1 mm (0.6 - 2 mm) No of slits / mtr: 8,600 Nos
Hub:	Polypropylene with 3/4" BSP inlet
Support:	R PVC pipe
Clamps:	SS 304 stepless clamps
Air flow:	Recommended: 8.5 to 10 cum/hr
Pressure:	Recommended: upto 1.0 kg/cm ²
SOTE:	< 3 mtr SWD : 4 to 5% per mtr > 3 mtr : 5 to 6.5% per mtr submergence

Features

- EPDM / Silicone blends ensure that membranes are more flexible and inflatable.
- The unique "I" slit design prevents back flow. When the blower is put off, the membrane dis-inflates and regains its smooth surface and does not allow ingress of particles.

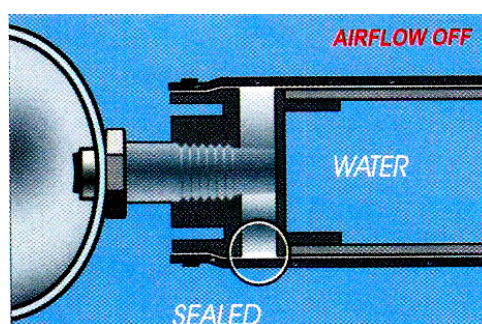
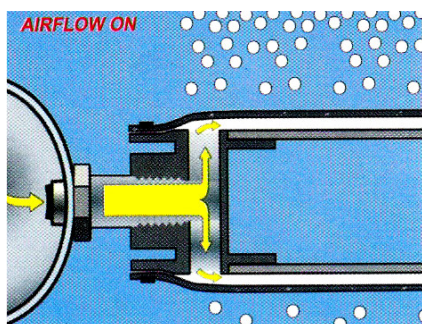

- The air flows and distributes only thro the two openings of the specially designed hub.
- Suitable for easy Retrievable arrangement - even without evacuating the tank.
- Convenient for Fixed type and Floating lateral type installations also.



ECOSAFE SOLUTIONS

F-122, Seetaram Complex, Subhanpura, Vadodara 390023, India

Call: +91-98242-12275 Fax: +91-265-2280902 e-mail: vp@ecosafeindia.com